



CFD Research Corp.

701 McMillian Way • Huntsville, Alabama 35806 • www.cfdrc.com

www.medicalavatars.com



A Multiscale Computational Framework for Inhalation Pharmacology and Drug Development

Narender Singh, Ravi Kannan and Andrzej Przekwas

Computational Medicine and Biology (CMB) Div.

CFD Research Corp., Huntsville AL 35806

Collaborative Project with FDA CDER, Office of Generic Drugs

FDA Project Officer Dr. Renish Delvadia

Grant no.: 5U01FD005214-02

Public Workshop:

New Insights for Product Development and Bioequivalence Assessments of Generic Orally Inhaled and Nasal Drug Product

FDA, January 09, 2018

- **CoBi** – Computational Physiology and Pharmacology
- **Multiscale** Computational Respiratory Pharmacology Tools
- Automated Generation of **Lung Model** (population)
- **Q3D** Simulations of Respiration and Aerosol Inhalation
- Airway **Barrier** Model
- **PBPK** Model and Validation Results for ICs
- Effects of Product **Formulation**
- Role of In Vitro **Dissolution** & Transport Models for **IVIVE**
- **Bioequivalence**
- Conclusions and **Recommendations**

Ocular drug delivery model

Multicompartmental High Fidelity

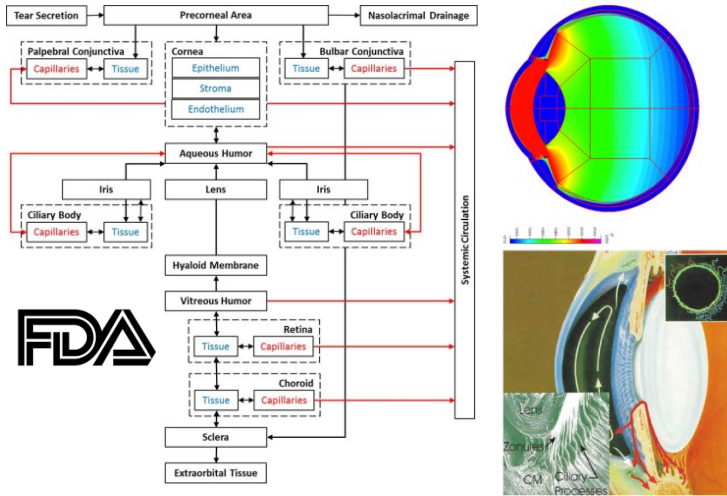

Pulmonary drug delivery model

High-fidelity CFD model Quasi-3D Wire model

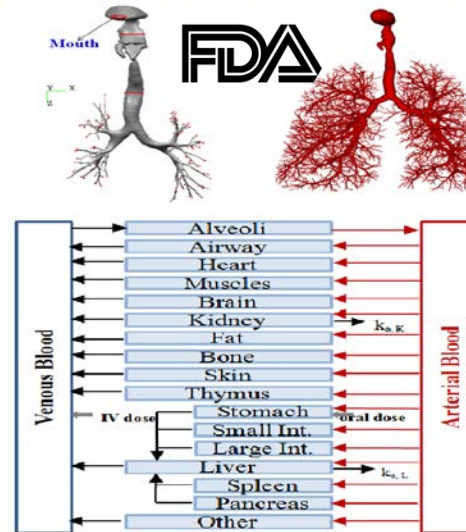

Transdermal drug delivery model

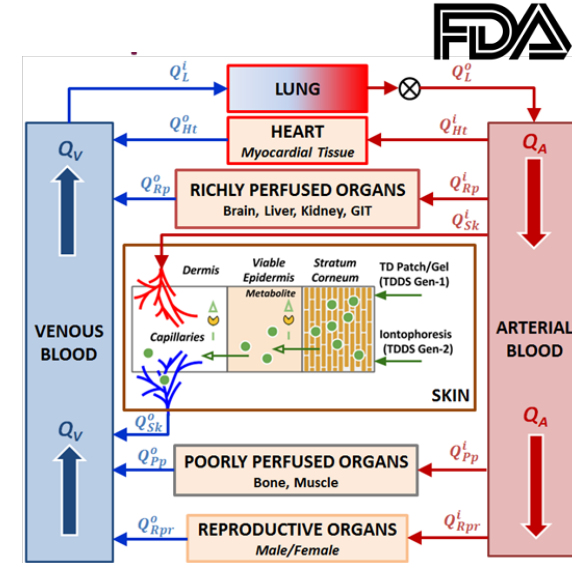

Cochlea drug delivery model

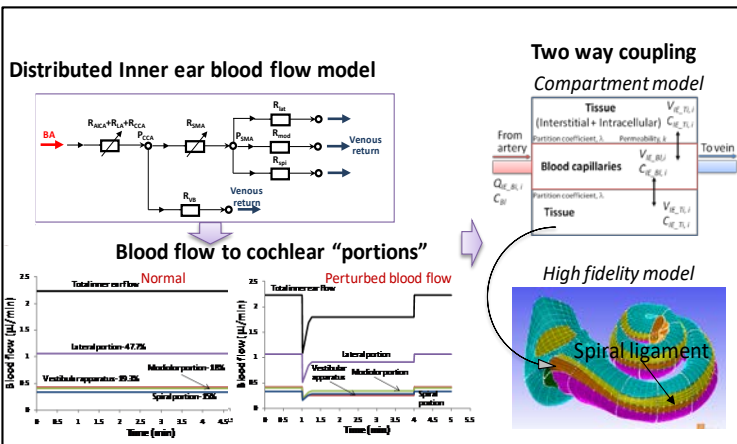

Oral delivery model

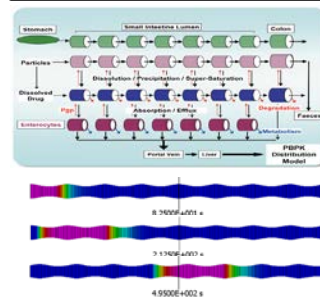

Nasal Vaccine model

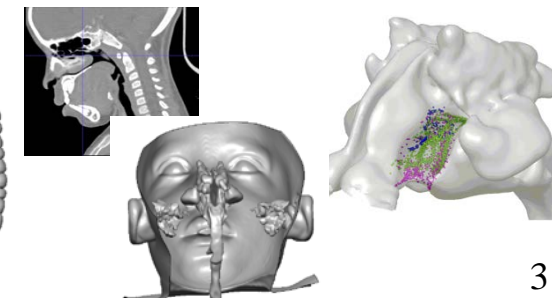

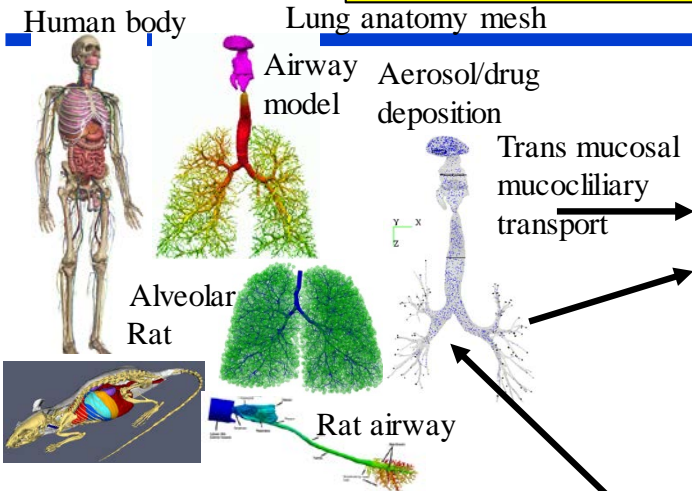

Pharmacokinetics

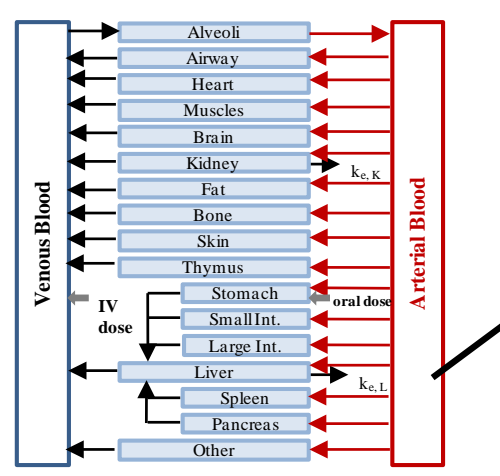

Biomarkers & diagnostics

Lung disease model
Disease progression



FeNO
Niox Vero
Bosch Vivatmo



CoBi-PharmaLab
PBPK/PD tools
on Android Tablet

Airway mechanics & disease

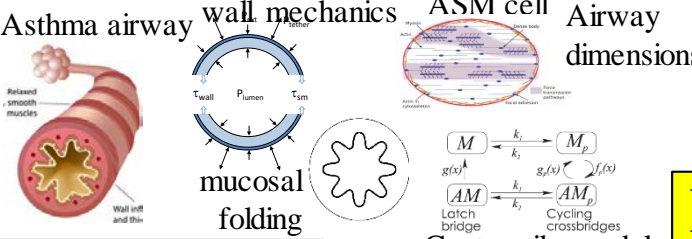

Mucosal barrier model

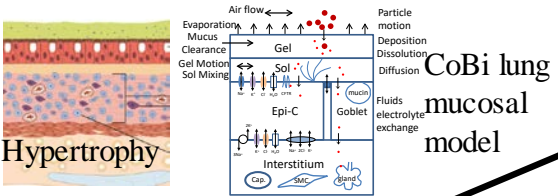

Drug/vehicle properties

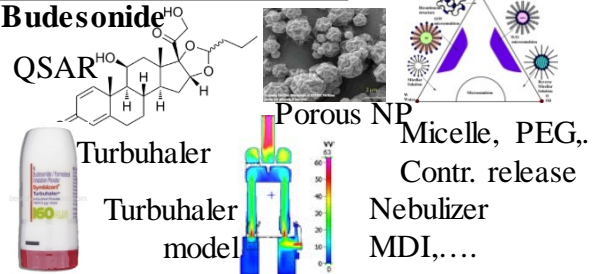

Pharmacodynamics

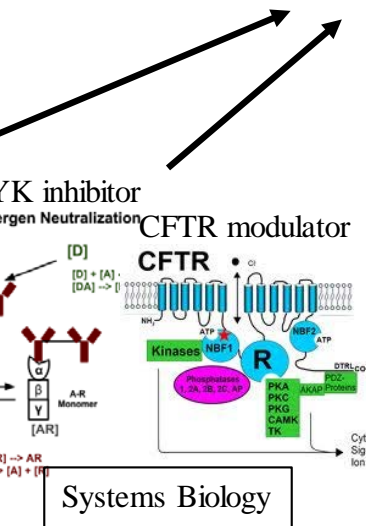

In vitro device/mode;
Wyss Lung on chip



CoBi Lung on chip model

Pharma End-user
High fidelity models



Human Lung Models (Geometry, 3D/Q3D Mesh)

Anthropometric data as inputs for body generation

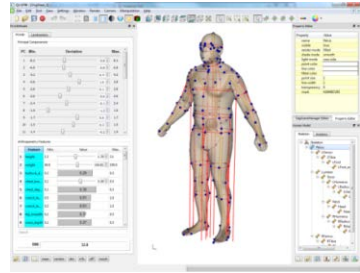

Population (personalized)



Extraction of body/thoracic parameters



Thoracic/lung imaging data to calibrate lung PCA

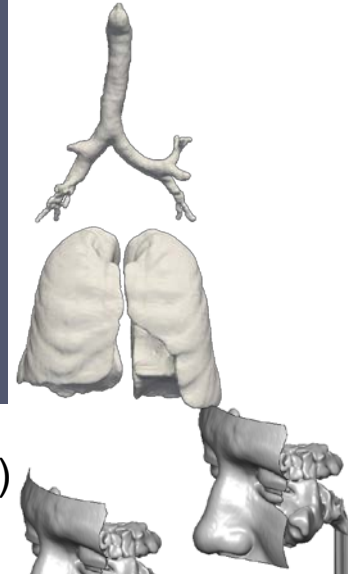

Proportional scaling of oral-pharynx (match trachea)

Spirometry inputs to calibrate lung respiration function (flow) (BCs)

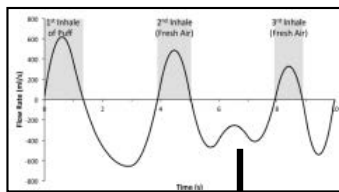

Propagate the airway bronchial tree to fit the lung lobes

Morph CFDRC Zygote HF airway to match Q3D

Generate airway Q3D model

Combine all 3

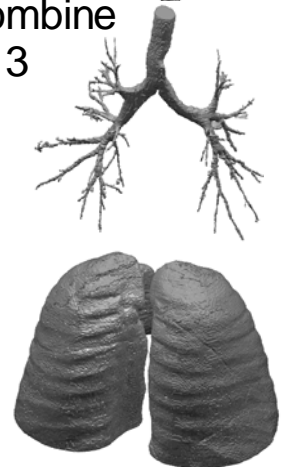

Generate Airway Mesh
 • 3D+Q3D for HF sim
 • Q3D for fast sim.
 • Aerosol inhalation & Deposition

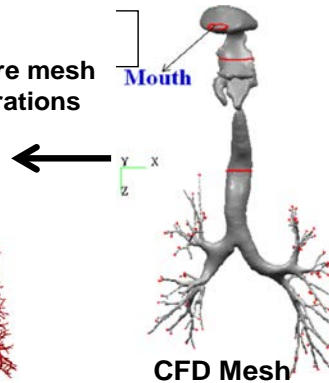
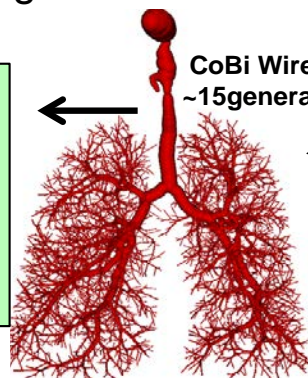

CFD Mesh

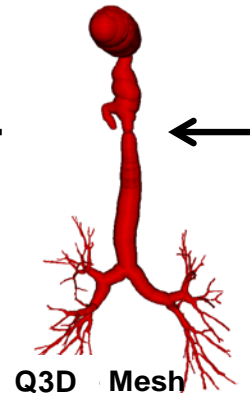

Q3D Mesh

- Develop, evaluate, and improve **physiologically-based absorption and pharmacokinetic models of pulmonary (inhaled) drugs**.
- Support the development and **evaluation of generic drugs**, products, and application review in this field.

Integrated computational framework for pulmonary drug delivery and PBPK-PD simulation.

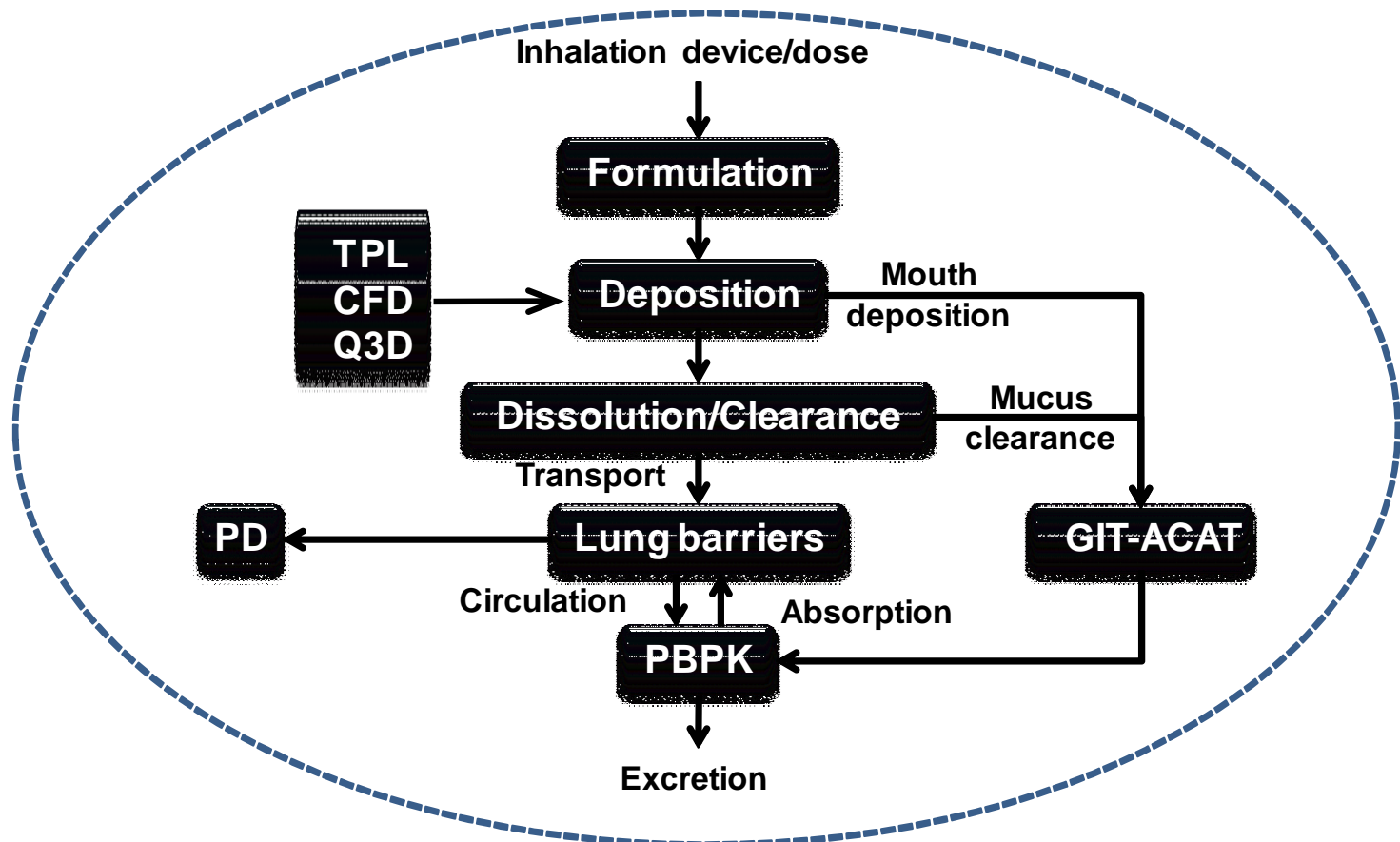

Drug Deposition: Airway lumen and wall models

- Empirical Typical Path Lung (**TPL**) model: Fast and can predict the drug property based particle depositions in the NOPL/TB/P regions for lung
- 3D **CFD** model/mesh: ~5-6 generations (200+ outlets!) : O(1.5M) cells
- Quasi-3D (**Q3D**) wire mesh: O(1500) cells
 - Robust, fast running and easily adaptable Quasi-3D wire mesh
 - Comprises of a structure of connected wires, with well-defined radii
 - Error margin: 5% (laminar)-10 % (turbulent); 10K fold speedup w.r.t. CFD
- **Applications:** Spirometry simulations & calibrations, Nitric Oxide calibrations, Distributed PKPD simulations

3D vs Q3D validation. Flow rate: 5L/min

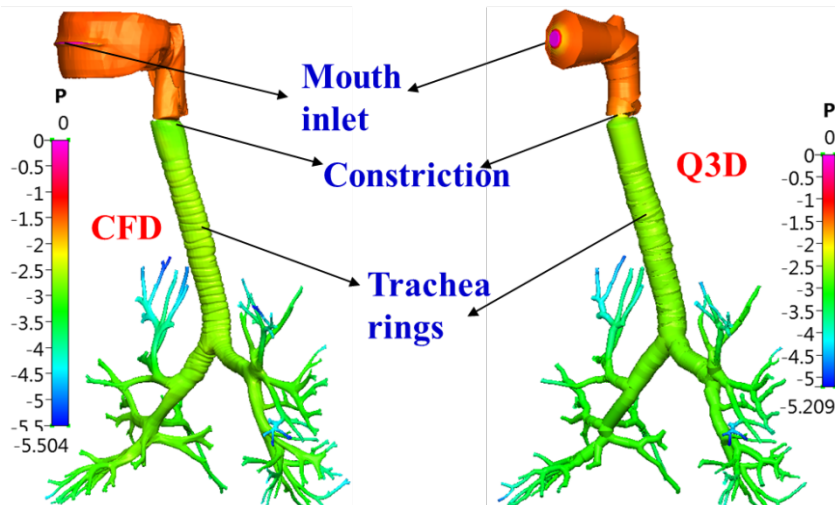

O₂ exchange animation, using Q3D model.

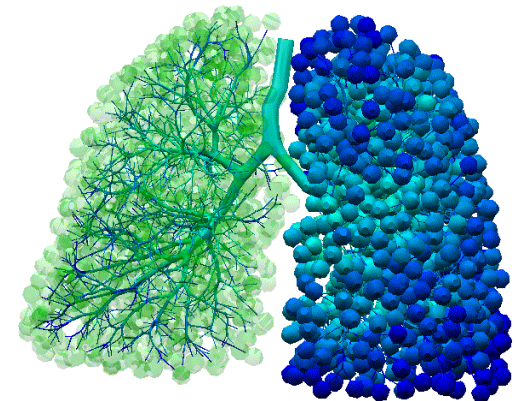

Drug Deposition: Lung barrier transport model

- **Rosania** model: Predict drug retention/transport across lung tissue
- Model considers drug **ionization**, **partition** into lipid components, and passive **diffusion** across the air-plasma barrier
- Processes are determined by **drug physicochemical properties** (e.g. logP, pKa) & tissue anatomy and physiological/pathological properties (**barrier thickness**)

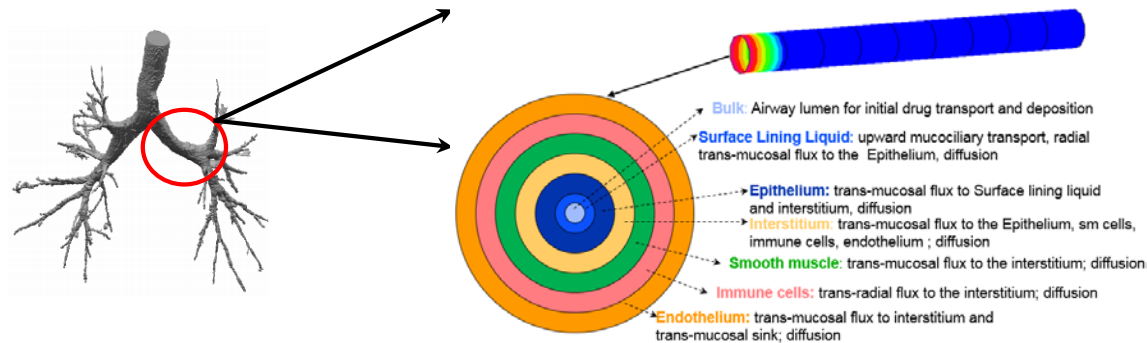
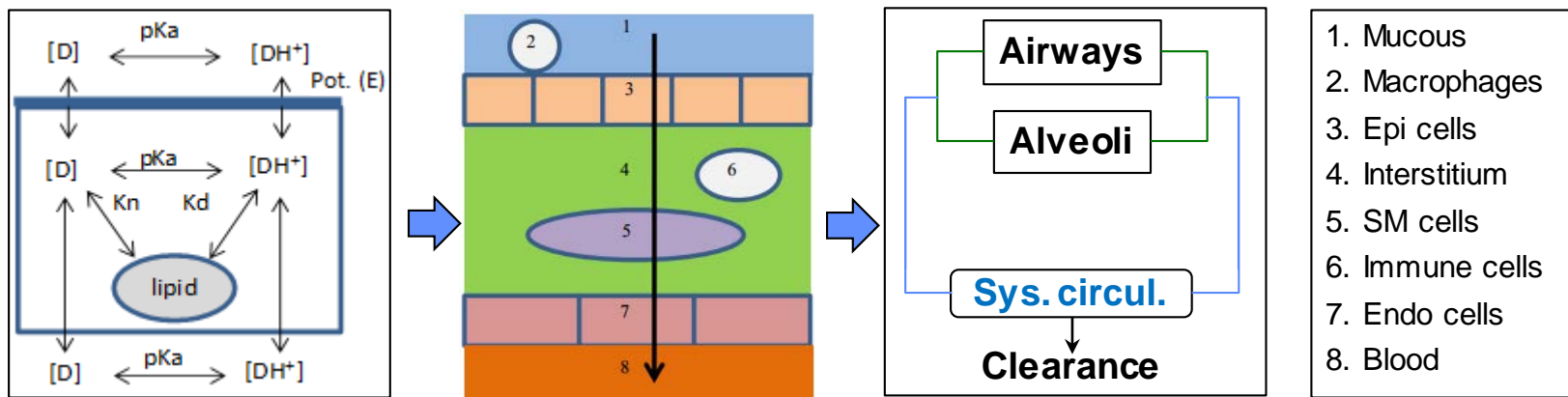

Q3D airway barrier model

Drug Deposition: Model comparisons

- CFD Model Geometry & mesh generation:
 - Represent **multiple generations**
 - Euler Lagrangian (**EL**) vs Euler Euler (**EE**) models
 - EL used mainly for **drug** depositions. EE for **aerosol** deposition.

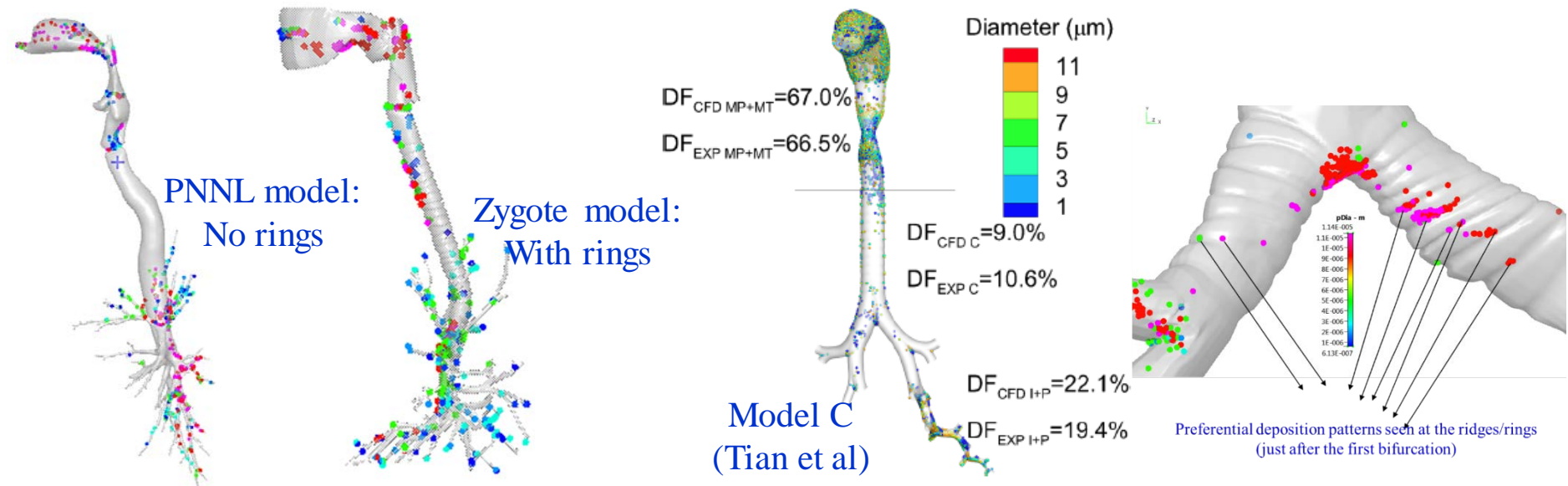

- Q3D model can get the depositions in different lung airways regions. Accurate for aerosol depositions. Full EE model
- **Currently developing EE** (CFD and Q3D) models for modeling prolonged inhalation of aerosols (minutes)

Deposition Validation: Budesonide Novolizer DPI

- Modeling **Budesonide** drug deposition on the human airways
 - Transient flow rate provided by the **Novolizer DPI**
 - Drug particle mass distribution (**polydisperse**) provided by the Novolizer DPI
 - **Good match** with previous published results (Tian et al) of % deposition

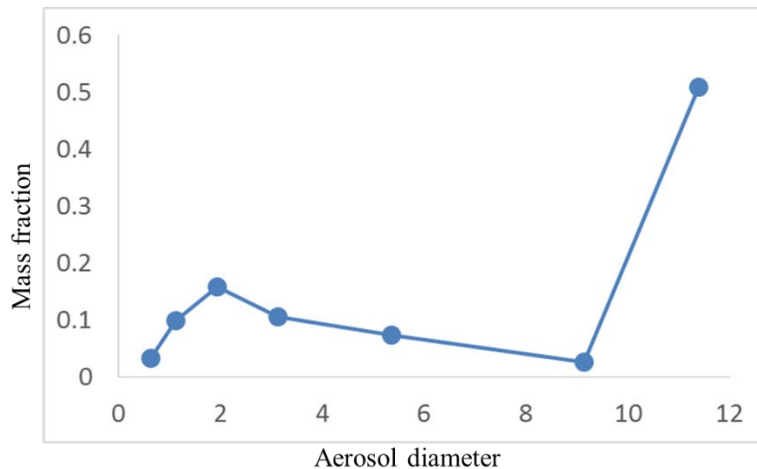

Mass fractions of the aerosol particle size distributions for the Novolizer (model inlet BCs).



Location	Tian et al	CFDRC	Cast
NOPL	67	56.54	66.5
Trachea-B3	2.7	4.68	
B4-B7	8.2	7.37	
NOPL to Gen7/8	77.9	68.45	

Novolizer deposition comparisons

Whole-body PBPK & Link to Deposition/Systemic

- Whole-body human PBPK: Central component of **drug ADME**
Connect lung barrier model (through blood compartment) and gut models
PBPK: 19 compartments that can test multiple delivery route
- **Gut model (CAT)**: Imp since the swallowed drug contributes to drug PK
9 segments connecting ‘stomach(1)-intestine(7)-colon(1)’

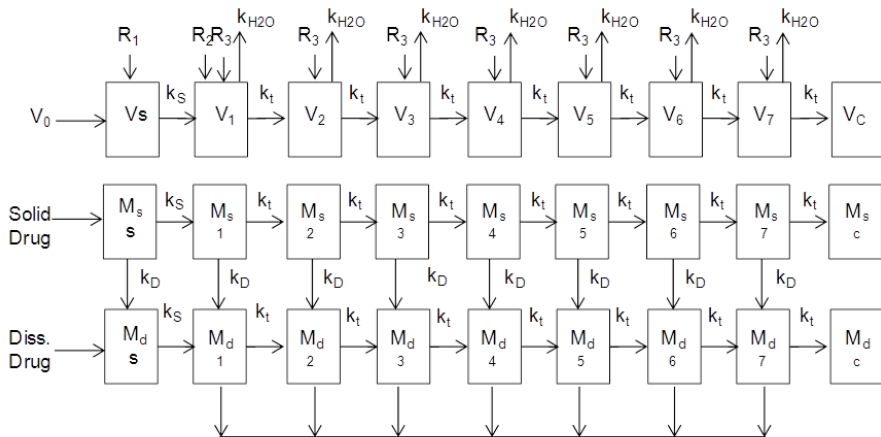

Gut (ACAT) model

Whole-body PBPK

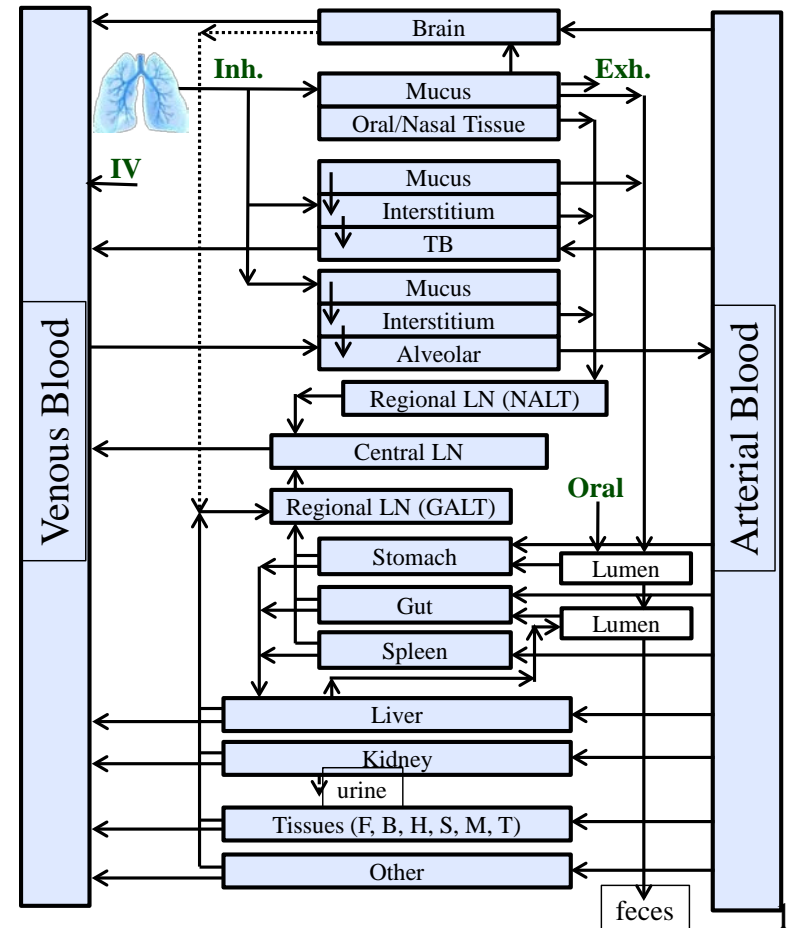

Full Framework Compartmental PK Validation

Parameters values for inhaled Mometasone Furoate (MF) & Budesonide

Parameters	MF	Budesonide
Particle density (g/cm ³)	1.23	-
MMAD of particles (μm)	2.2	-
Molecular weight	427.4	430.5
Intestinal permeability(cm/hour)	0.11	-
Solubility (μg/mL)	5.23	45
B2P	0.55	0.90
Protein Binding	98-99%	85-90%
fu	1.5%	12.5%
Liver extraction rate	99%	80%
Half-life time after IV (hour)	4.5	2.0-3.6
First Pass Effect	99%	10-20%
Clearance rate after IV (ml/min)	892	

- Types of drugs : ICs, Beta-2 agonists (short/long acting), Anticholinergics

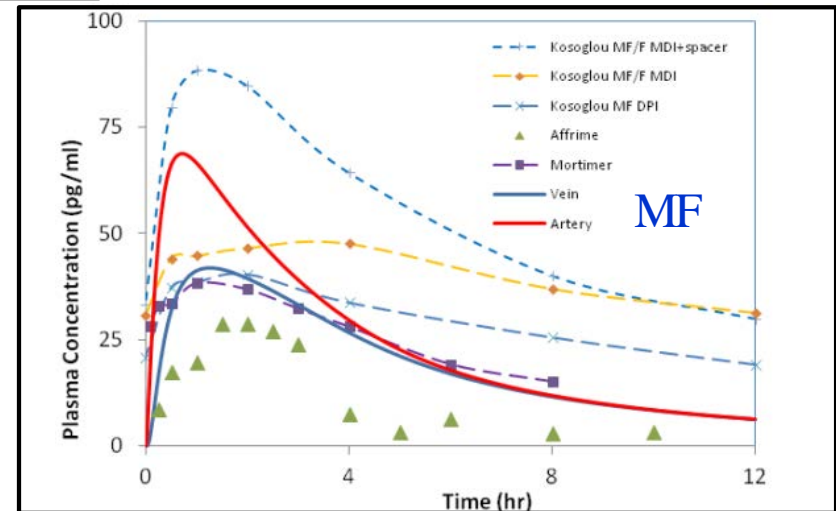
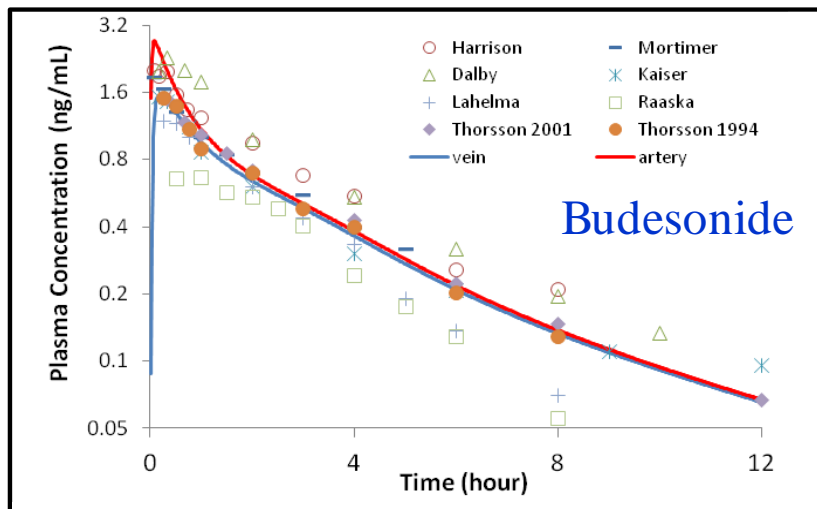

Budesonide plasma conc. after 1000 μg **inhalation** dose. Plotted are the various experimental data normalized (for some) to dose of 1000 μg.

MF plasma conc. after 400 μg **inhalation** dose. Plotted (solid circles) are the experimental data from literature

Thorsson, *BJP*, 52(5), 2001; Thorsson, *ERJ*, 7(10), 1994; Thorsson, *BJCP*, 47(6): 1999; Affrime, *JCP*, 40(11), 2000; Harrison, *Thorax*, 58(3), 2003; Dalby, *RR*, 10(1), 2009; Lahema, *BJCP*, 59(2), 2005; Mortimer, *BJCP*, 64(4), 2007; Kaiser, *BJCP*, 48(3), 1999; Raaska, *CPT*, 72(4), 2002

Affrime, *JCP*, 40(11), 2000; Mortimer, *BJCP*, 64(4), 2007; Kosoglou, *IJCPD*, 8, 2013

Integrated Multiscale Lung-PBPK Model (Budesonide)

- Budesonide: 1mg Budesonide inhalation (DPI): healthy cases
- Deposition values: From CFDRCs novalizer results and Tian et al
- Good match with experiments. **AUC** and **C_{max}** are within experimental range
- **Shape/Slope** and **AUC** obtained from the multiscale model are better than the compartmental model

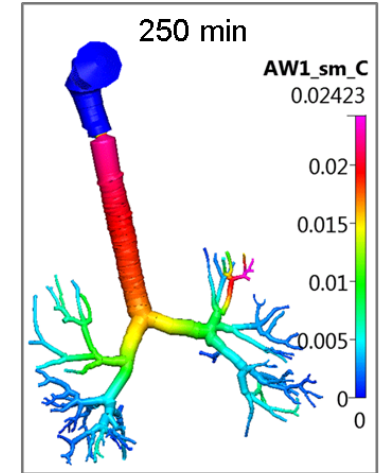
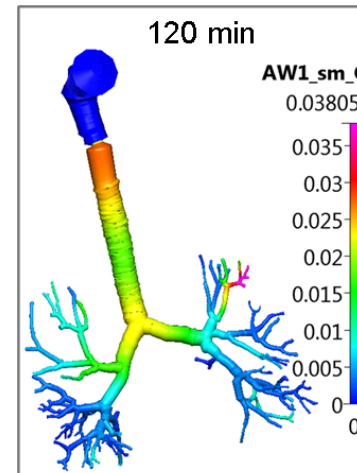
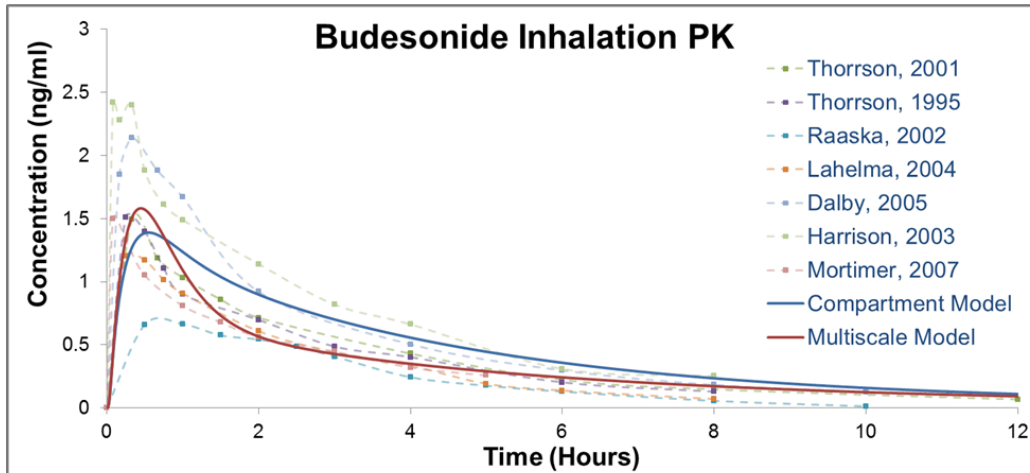

Inhalatory drug PK (healthy): Compartmental & multiscale simulations versus experimental PK values

Concentrations in airway smooth muscle (AW_{sm}) cells

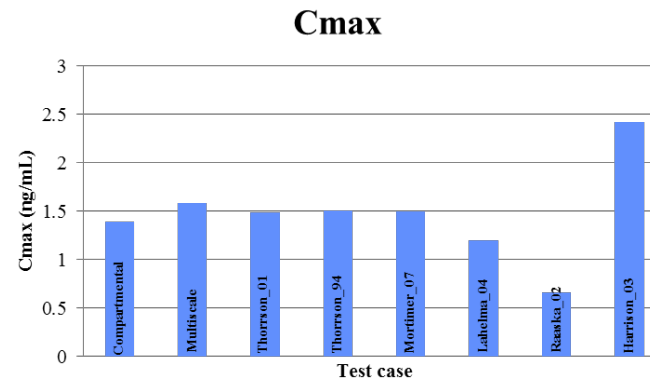
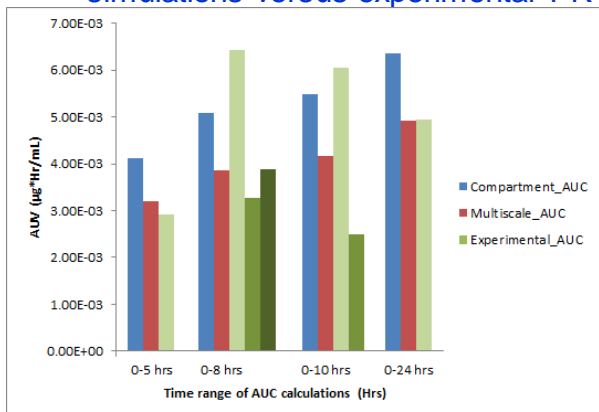

AUC and C_{max} comparison of compartmental and Q3D simulations vs experiments

Integrated Multiscale Lung-PBPK Model (FP)

- Fluticasone propionate: 1mg FP inhalation (DPI): healthy case
- NOPL region has around 72-78% (Exp). We scaled the OPL region to 75%
- Very low systemic bio-availability and solubility (1/100th that of Budesonide), i.e. dissolution time in mucosa is >8 hrs for FP compared to 6 mins of Budesonide

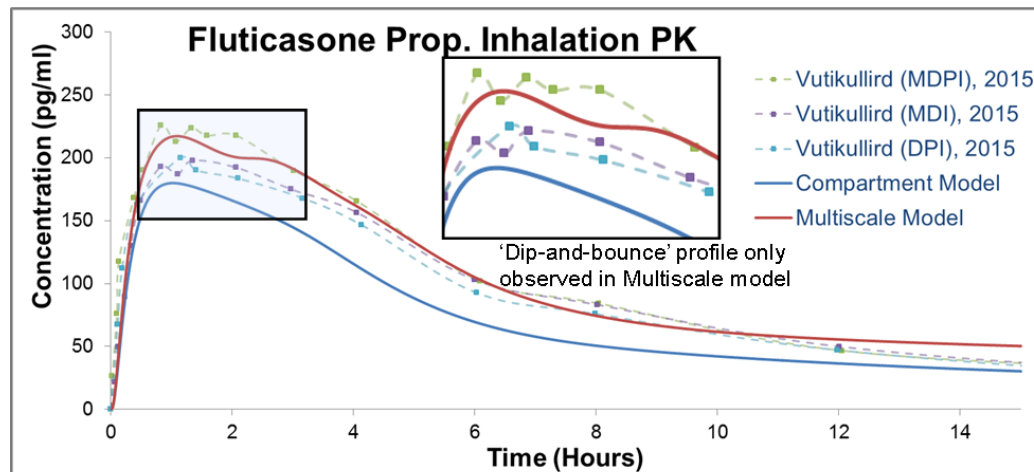

Inhalatory drug PK (healthy): Compartmental & multiscale simulations versus experimental PK values

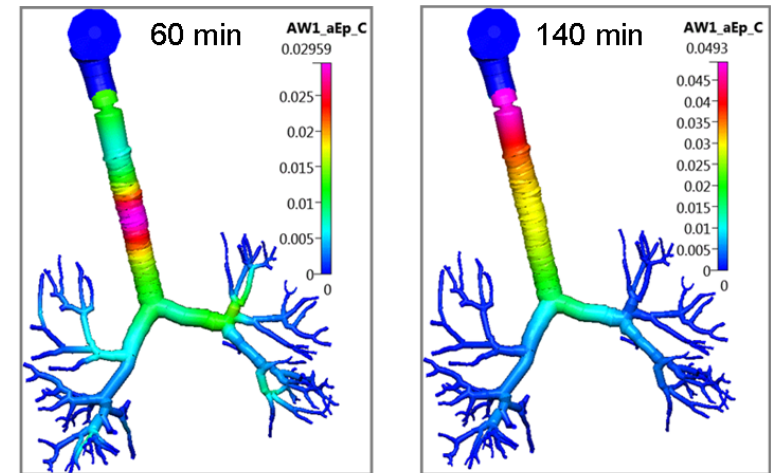

Concentrations in airway apical-epithelial (AW_aEp) cells; Note the appearance of blobs, unlike the Budesonide case (due to poor solubility)

- Conc. in the vein is much lower than the Budesonide simulations due to low solubility
- In both cases (compartmental vs multiscale), the initial rise is the same, since it is dictated by the GUT model (since the drug transport to the GUT is very fast and the low dissolution and transport across the lung walls is a slow process)
- **DIP-AND-BOUNCE** phenomenon is observed only in the multiscale model (similar to experiments).

Pharmacodynamics Modeling (PD)

- PD is done in-sync with the current 7 layer Rosania's PK model for **each airway section G0-G15** (*Gaz et al. J Pharmacokinet Pharmacodyn* 2012, 39:415–28)
- The adapted model **computes the diameter as a function of time** based on the mass of the drug at time t & the location z and the potency of the drug to keep the diameters relaxed
- PD was **done on both compartmental and Q3D frameworks** (both formats needs more rigorous validation and parameter fitting etc. based on experimental data – not available)

$$\frac{\partial D_i}{\partial t} = K_{DRUG} \frac{C_i}{C_{MAX}} N_{RECEPTORS} A_i - K_{DISEASE} B_i$$

$$A_i = D_i < DH_i ? DH_i - D_i : 0$$

$$B_i = D_i > DD0_i ? D_i - DD0_i : 0$$

i = The generation number

K_{DRUG} = Rate coeff. describing the drug potency

C_i = Conc. of the dissolved drug in that region

C_{MAX} = Scaling coeff.

$N_{RECEPTORS}$ = # of ASM receptors/unit-volume.

$K_{DISEASE}$ = Rate coeff. that forces the diameters to return to their pre-drug levels

DH_i = Diameter of the healthy specimen at Gen # i

$DD0_i$ = Diseased diameter prior to drug inhalation

- **Test case:** 1000 μ g Budesonide inhalation, assuming a uniform 20% diameter shrinkage (non-uniform can also be handled); (180000 ~ 2 days)
- Lower airways have the least amount of the dissolved drug
- Consequently, difficult to maintain the “relaxed” diameter levels at these locations.

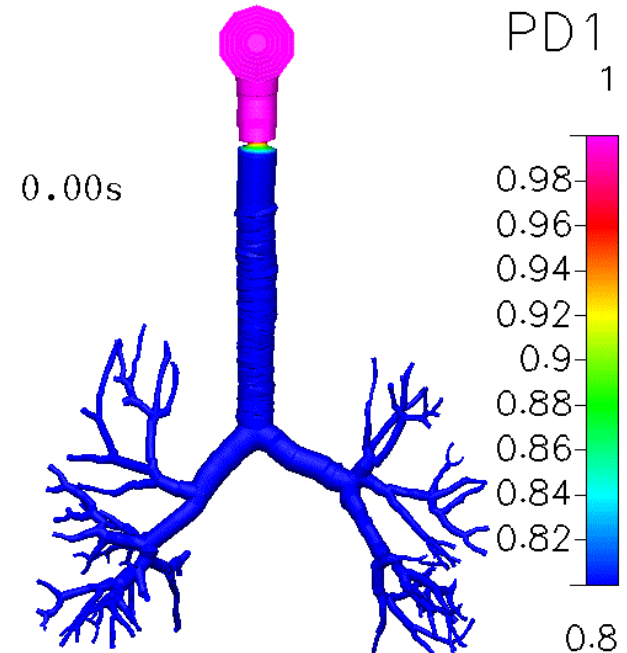

Local non-dimensional lung diameters 15

Formulation Effects on PK

- **Two types** of formulation effects on PK: Physiochemical and FPF%
- **Physiochemical property related changes: logP, mmad, fu etc.**
- **Carrier related changes: Effect FPF%**

fu: fraction of unbound drug in plasma - Driving force behind the transport of the drug from lung to plasma;

B2P: (blood-to-plasma partition ratio) Drug partitioning in the blood cells (RBC);

logP (hydrophobicity): Influence the transport rate of the drug through various physical compartments after dissolution;

mmad: mass-median particle diameter that has 50% of the aerosol mass residing above and 50% of its mass below it

Pulmonary (lung) concentration ($\mu\text{g/ml}$);

Varying f_u

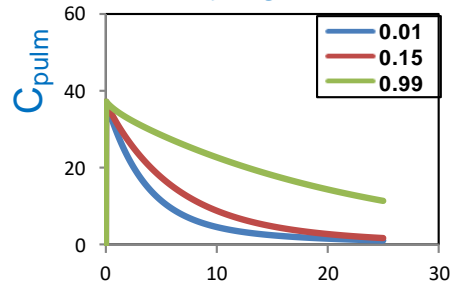

Varying B2P

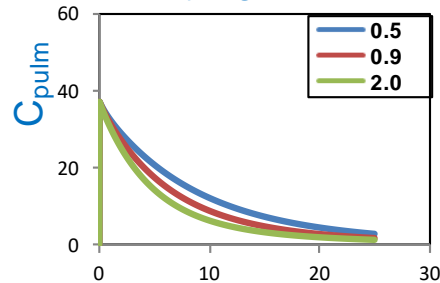

Varying logP

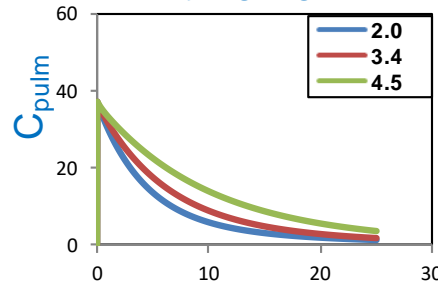

Varying mmad

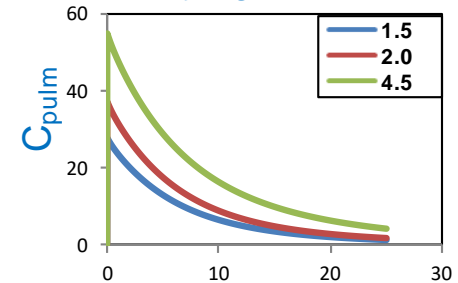

Systemic (plasma) concentration ($\mu\text{g/ml}$)

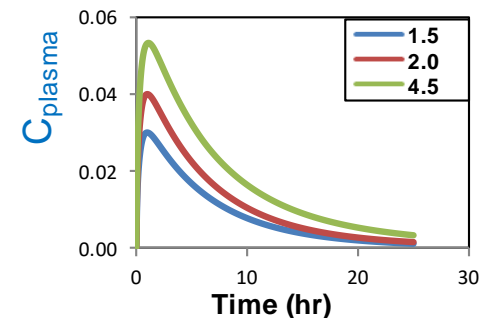
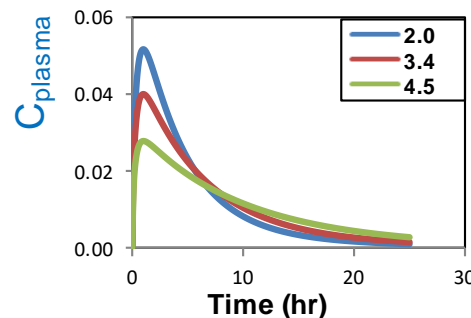
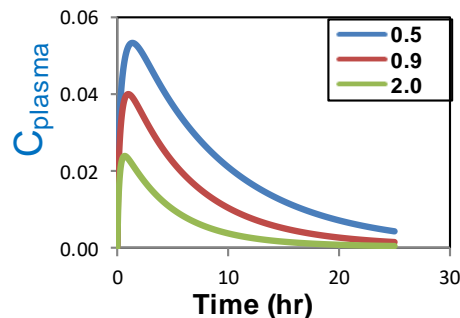
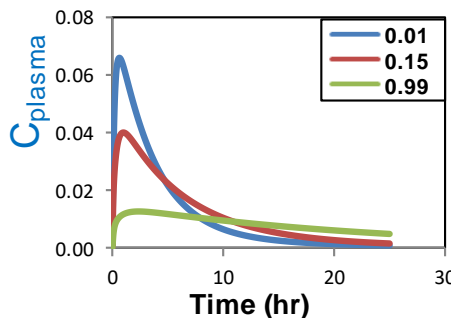

Formulation Effects on PK

- **Two types** of formulation effects on PK: **Physiochemical** and **FPF%**
- **Physiochemical** property related changes: logP, mmad, fu etc
- **Carrier related changes: Effect FPF%**
- **Most formulation effects are through FPF% in literature**
- Variation in FPF is calculated through empirical modeling of **28 various formulation factors (variables)**.

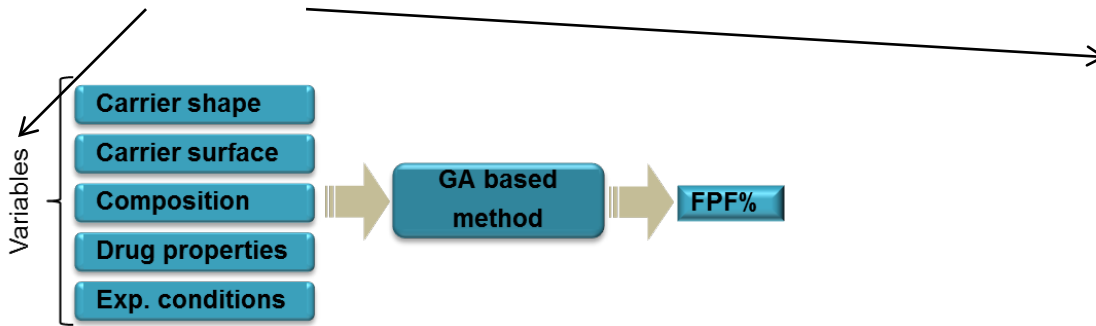

FPF (%) =

$$\begin{aligned} & ((-C7+C17+C4-C14-C16- \\ & \text{EXP}(C27))/((C25-C5))-(C18/((C32- \\ & C27*(C18)^{(C33/2)}*(C25-C5))))+((C17- \\ & C6*C21)^{C4})/(\text{LN}(C16)*(C25-C5)) \end{aligned}$$

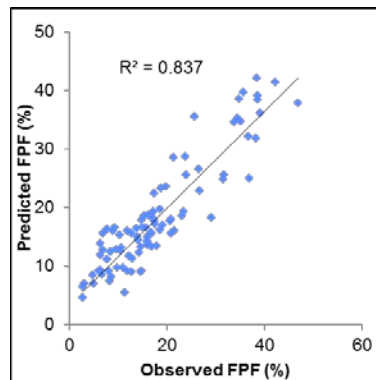

Variable group	Variable name	Variable sign	Budesonide values
Exp condition	Impactor type	C1	1
Quant composition	Mannitol content	C2	0
Quant composition	Lactose content	C3	0
Quant composition	Hydroxyapatite content	C4	1
Carrier surface	Rsk	C5	0.1069
Carrier surface	Rku	C6	0.16502
Carrier surface	Rv	C7	-88.20639
Carrier surface	Rp	C8	101.8989
Carrier surface	FPO	C9	76.74887
Carrier surface	FAD	C10	115.48009
Carrier shape	Feret	C11	29.867
Carrier shape	FeretAngle	C12	37.549
Carrier shape	MinFeret	C13	26.116
Carrier size	Carrier Size D10 [um]	C14	24.12
Carrier size	Drug Size D90 [um]	C15	1.57
Quant composition	Drug particle content (m/m%)	C16	9.09
Exp condition	Flow rate (L/min)	C17	30
Exp condition	Type of inhaler	C18	3
Drug properties	Smallest ring size	C19	5
Drug properties	Mass	C20	430.5339
Drug properties	Water accessible surface area	C21	143.72
Drug properties	Water accessible surface area hydrophobic	C22	451.51
Drug properties	Asymmetric atom count	C23	9
Drug properties	Balaban index	C24	1.29
Drug properties	Minimal projection radius	C25	5.14
Drug properties	Parameter count	C26	8
Drug properties	logP	C27	2.73
Drug properties	Hydrogen bond donor at pH = 12.00	C28	1.98
Eq constants	Constant1a	C1a	3.483513
Eq constants	Constant2a	C2b	1.081496
Eq constants	Constant3a	C3c	1.570966
Eq constants	Constant1	C1	23.84648
Eq constants	Constant2	C2	3.456648

Formulation FPF effects on PK

- FPF was further used to enhance compartmental and Q3D approaches through **multiple “bins”** to induce the poly-disperse effect on **Budesonide and FP** (not shown) drugs

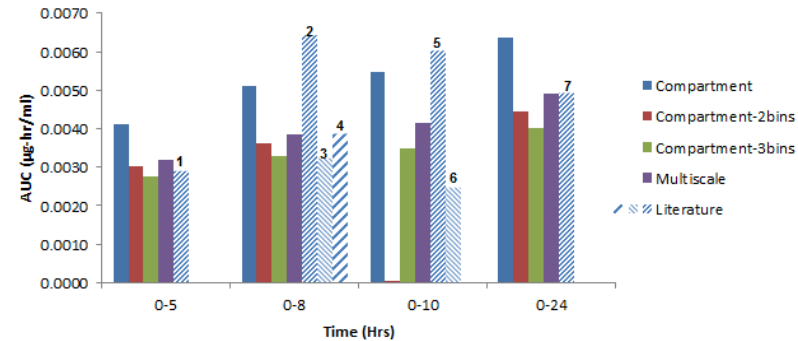
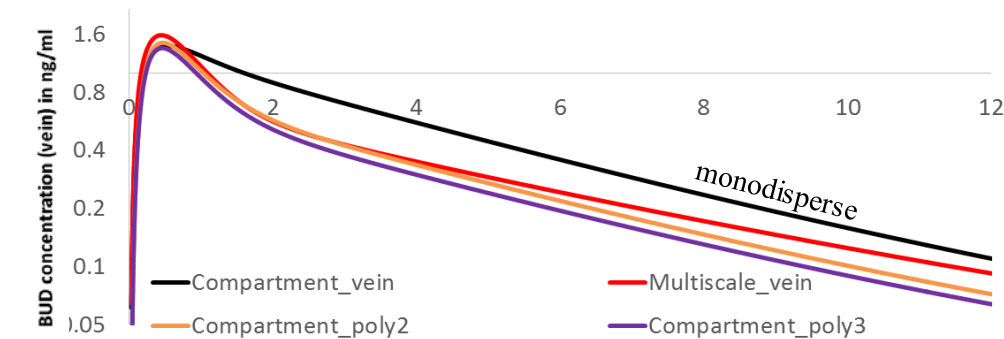
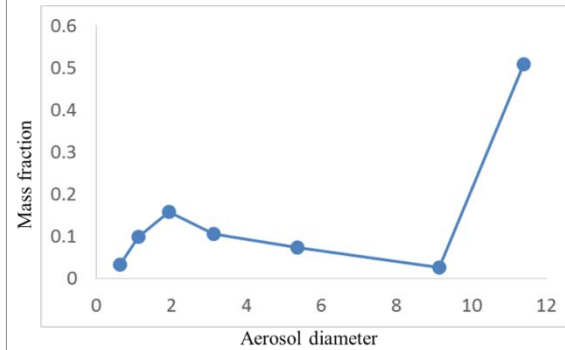
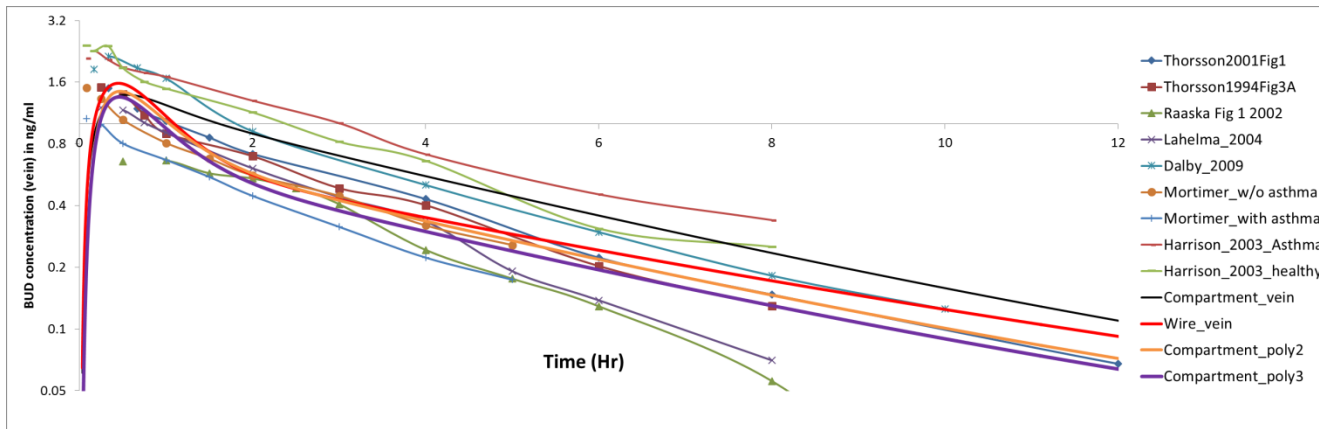

- (1) Mortimer, 2007
- (2) Harrison, 2003
- (3) Lahelma, 2004
- (4) Thorsson, 1994
- (5) Dalby, 2009
- (6) Raaska, 2002
- (7) Thorsson, 2001

- A much better agreement, using the poly-dispersed compartmental model
- Just 2 bins are sufficient to get qualitatively good results.
- Can be used for performing formulation specific simulations: using the FPF Equation

Dissolution Modeling of Drugs Using Transwell

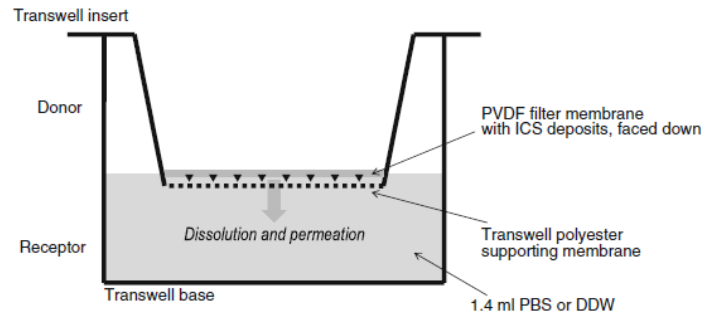

Transwell Schematic

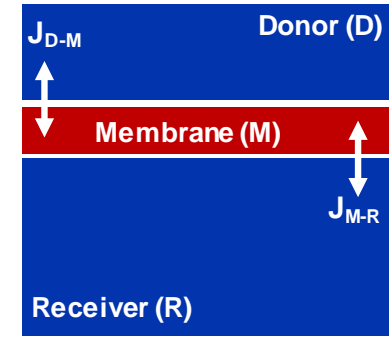

Dissolution model: The dissolution of the solid particles is modeled using the **Noyes-Whitney Equation** or the **Nernst-Brunner Equation**.

$$\frac{dm_d}{dt} = \sum_{i=1}^n \frac{DA_i(t)}{h_i(t)} \left(C_s - \frac{m_d}{V} \right)$$

- D – Diffusion Coefficient
- $A_i(t)$ – Surface Area of a Particle
- $h_i(t)$ – Thickness of Diffusion Layer
- C_s – Solubility
- m_d – Dissolved Mass

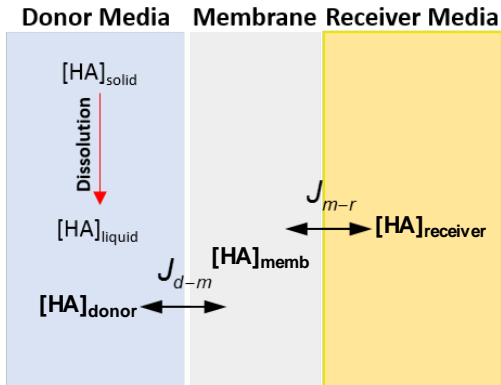

Mathematical model of a Transwell.

Donor media concentration:

$$V_d \frac{dC_d}{dt} = -J_{d-m} + \dot{m}_{dissolved}$$

Membrane Concentration:

$$V_m \frac{dC_m}{dt} = J_{d-m} - J_{m-r}$$

Receiver Media Concentration:

$$V_r \frac{dC_r}{dt} = J_{m-r}$$

Diffusive Fluxes Across the Interfaces:

$$J_{d-m} = A \frac{1}{\frac{\delta_m}{D_m} + \frac{\delta_d}{D_d}} (C_d - C_m) \quad J_{m-r} = A \frac{1}{\frac{\delta_m}{K_p D_m} + \frac{\delta_r}{D_r}} (C_m - C_r)$$

- V_d – Donor Media Volume
- V_m – Membrane Volume
- V_r – Receiver Media Volume
- C_d – Donor Media Concentration
- C_m – Membrane Concentration
- C_r – Receiver Media Concentration
- J_{d-m} – Diffusive Flux: Donor to Membrane
- J_{m-r} – Diffusive Flux: Membrane to Receiver

a. Dissolution behavior can be modeled using the physico-chemical properties of the drug

Properties of Budesonide	
MW	430.534
logP	2.5
Solubility	17 µg/ml
User Inputs	
Initial Mass	1.7 µg
Particle Size	2.5 µm

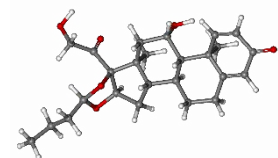
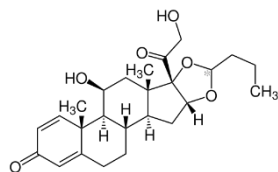

b. Mathematical models of the Transwell were developed using both ODE and PDE based formulations

$$\frac{\partial C}{\partial t} = \frac{\partial}{\partial x} D \frac{\partial C}{\partial x} + S \rightarrow \text{Source or Sink term (efflux, metabolism etc.)}$$

CFDRC's CoBi Framework solves PDE transport equation simultaneously in the entire domain i.e., from the top free media surface of the donor compartment, through the membrane to the bottom of the receiver reservoir

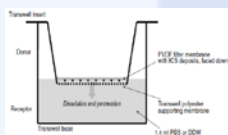
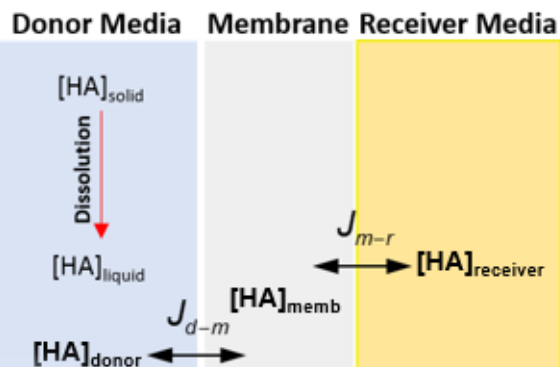

Dissolution behavior of Budesonide

Simulation vs Experiments

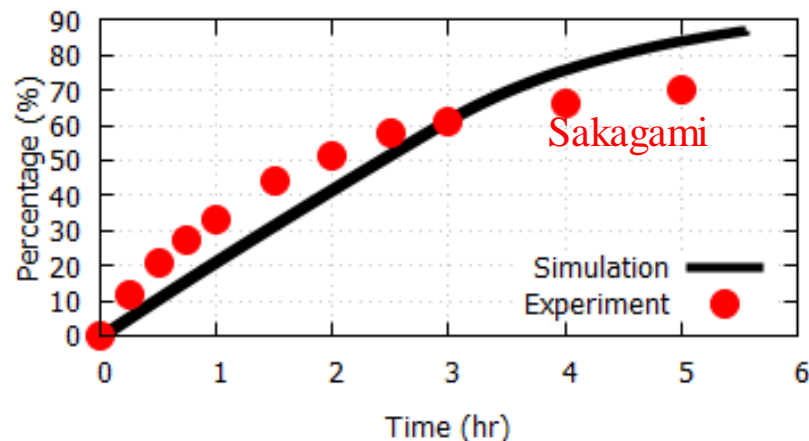

**The slight difference between the experimental result and the simulation prediction might be due to the assumption made here. These include:

1. Receiver compartment is unstirred
2. Samples taken from the bottom of the receiver compartment

Experimental data was extracted from

Arora, Deepika, Kumar A. Shah, Matthew S. Halquist, and Masahiro Sakagami. "In vitro aqueous fluid-capacity-limited dissolution testing of respirable aerosol drug particles generated from inhaler products." *Pharmaceutical research* 27, no. 5 (2010): 786-795.

Conclusions and Recommendations



- Developed and **multiscale simulation framework** for inhalation pharmacology - - inhalation, deposition, dissolution, absorption, transport and systemic PBPK
- Established novel aerosol inhalation and deposition simulation framework **combining 3D and Q3D** approaches
- Developed **healthy and diseased** state lung models based on experimental data
- Demonstrated **formulation effects** and physiochemical parameter effects on pulmonary and systemic circulation
- **Validated** the integrated framework on several inhaled **corticosteroids/others**
- CoBi Inhalation Pharmacology and **GUI tools** as an Open Source framework
- **Future:**
 - Modeling of **non-ICS** inhalation drugs and drug **combinations** of ICS and non-ICS
 - Establish a computational platform for **IVIVE** for inhalatory delivery of drugs
 - Study the effects of specific inhalatory drug formulations (**bioequivalence**):
carrier effects: density, aerodynamics, agglomerate sizes, type of carrier (mannitol, lactose, sorbitol): How carrier binding effect drug dissolution
- **Establishing FDA funded tools as free access Weblets for in vitro and in vivo Inhalation Pharmacology**

Weblet – Drug Dissolution-Permeation in a Transwell



Free interactive access to web-based and cloud computing using CoBi tools and Inhalation Pharmacology models

medicalavatars.cfdrc.com/index.php/ode/

MedicalAvatars.com Computational Medicine & Biology Mobile Apps Weblets Surrogates Downloads News Contact Us

Drug Dissolution in Transwell

Initial mass (ug)
1.7

Particle size (um)
2.5

Molecular Weight (g)
380

Density (kg/m3)
1270

Solubility (ug/ml)
17

Time (s)
18000

Submit Reset

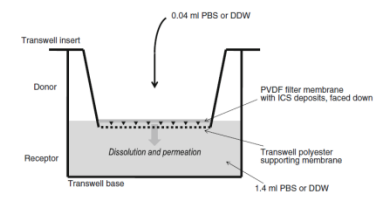
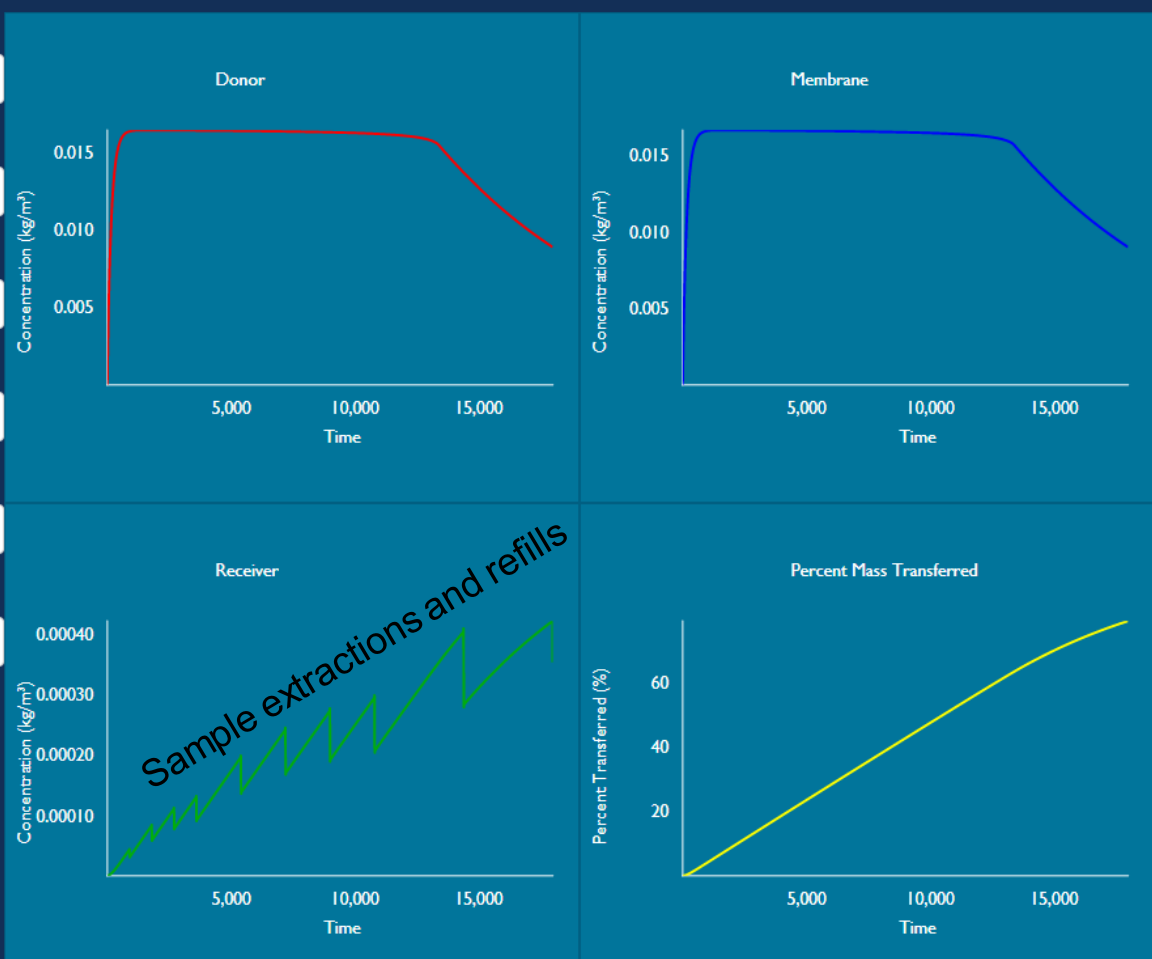

Test case- Budesonide
Dissolution/permeation of aerosol particles of inhaled ICSs in the Transwell® system
Arora et al (2010)
Pharm Res 27(5):786-95

Thank You

Questions?